

INSTRUCTIONS FOR O.S. FS-120 SURPASS FOUR STROKE CYCLE ENGINE

IMPORTANT: Before attempting to operate your FS-120 Surpass, please read through these instructions so as to familiarize yourself with the controls and other features of the engine. Also, pay careful attention to the recommendations contained in the "Safety Instructions and Warnings" leaflet enclosed.

The entirely new high-performance FS-120 'Surpass' model has the unusual refinement of a specially developed O.S. mechanical fuel pump built into the crankcase backplate. This ensures that fuel is delivered to the carburettor at the pressure necessary to maintain optimum mixture strength, irrespective of fuel tank location or aircraft attitude.

Because delivery of fuel to the carburettor jet is no longer dependent on the suction created by a reduced venturi size, a special large-throat carburettor (O.S. Type C-12) is installed to improve the engine's breathing and further enhance its power output.

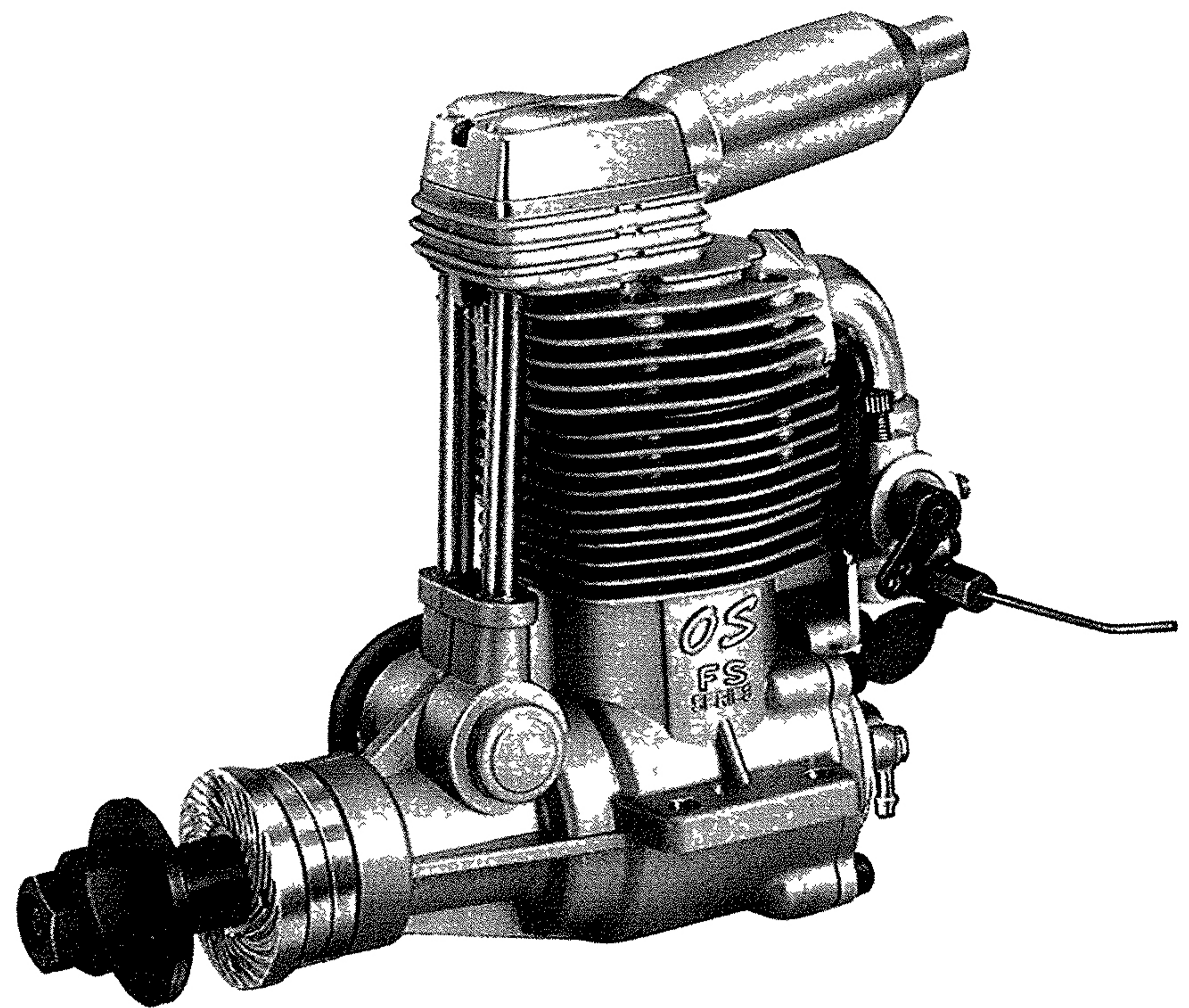

SPECIFICATIONS

Displacement	19.96 cc (1.218 cu.in.)
Bore	30.4 mm (1.197 in.)
Stroke	27.5 mm (1.083 in.)
Practical RPM	2,000 – 12,000
Power Output	2.1 BHP/12,000 r.p.m.
Weight	945 g (including silencer)

INSTALLATION

Use sturdy engine mounting beams: i.e. at least as strong as would be used for a two-stroke engine of 15cc, or greater, displacement. Make sure that these beams are firmly integrated with the airframe, reinforcing the internal surrounding structure as necessary to absorb vibration. Engine installation should be made in such a way that basic maintenance, including the checking and adjustment of valve clearances, can be conveniently carried out. As an aid to aligning the engine on its mounting beams, a simple mounting hole template is supplied with the engine.

As an alternative to horizontal beam mounting, a special O.S. radial motor mount is available, as an optional extra part, for use where firewall mounting is required.

SILENCER ASSEMBLY

Installation procedure is as follows.

1. Secure the exhaust header pipe by screwing the union-nut over the cylinder-head exhaust-stub. Adjust the header pipe to the required angle, then tighten the union-nut firmly with the 17mm wrench supplied.
2. Screw the silencer onto the end of the header pipe and tighten locknut firmly.

Note: It is advisable to apply silicone sealant at the joints to prevent leakage of exhaust gas and loosening of nuts.

CHOKE VALVE

The FS-120 Surpass is equipped with a spring-loaded choke valve. The choke valve operating lever can be located right or left by transposing the hexagon nut and cap screw.

After mounting the engine in the model, secure the L-shaped choke rod by tightening the set-screw. If the rod supplied is too long, reduce it to the required length. If the rod length is more than 40mm (1½ in.) its outer end should be supported to avoid vibration.

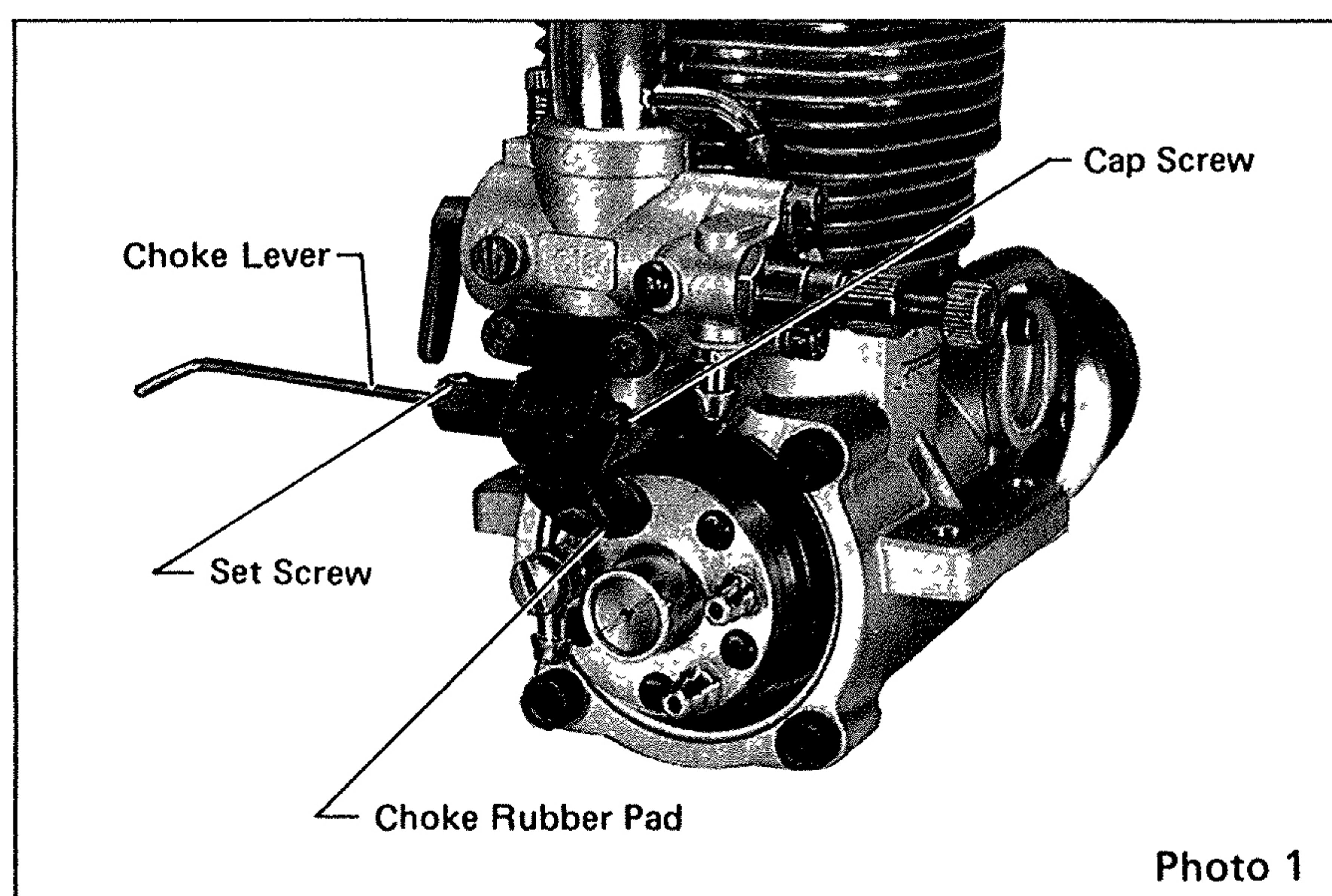

FUEL

The FS-120 Surpass runs on standard commercially available model glowplug engine fuel. Fuels containing castor-oil and/or synthetic lubricants are acceptable, but for the best performance and reliability, a fuel containing 5 – 15% nitromethane is recommended.

FUEL TANK

The suggested fuel tank size is 400cc or 14 oz. This will give approximately 10 minutes running time for FAI pattern flight.

If the fitting of the 'klunk' type fuel pick-up weight in the fuel tank is incorrect, the weight may stick to the tank wall, resulting in an irregular fuel flow to the carburettor, or, alternatively, in the fuel flow being cut off during the course of sharp aerobatic manoeuvres. Therefore, it is advisable to make slots in the end of the weight, with a file or hacksaw blade, as shown in Fig. 2. Thoroughly wash out the weight to remove any minute particles of metal before re-installing it in the tank.

Note: If the end of the return pipe is not immersed in fuel, use of the choke valve will be ineffective. Therefore, if, for any reason, you have occasion to start the engine with the aircraft in the upside-down position, it will be necessary first to choke the engine while the model is in the normal upright position.

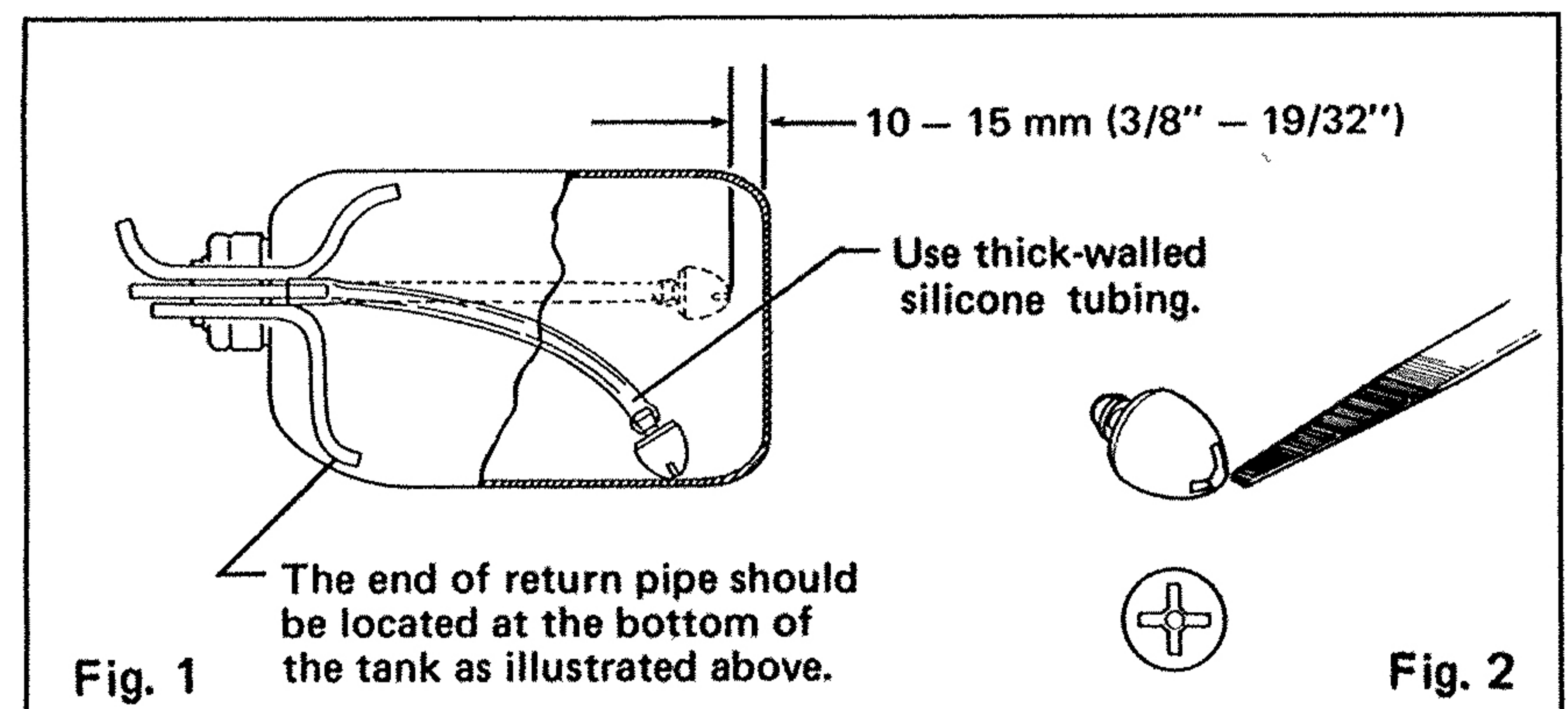

PIPING

For piping, use heavy duty silicone fuel tubing of approximately 2.5mm I.D. and 5mm O.D. It is advisable to secure the connections with double tubing or commercially available tubing clips.

Tube lengths, except Pipe C (see note below), should be kept as short as possible. Take care not to cause any kinks in the "plumbing".

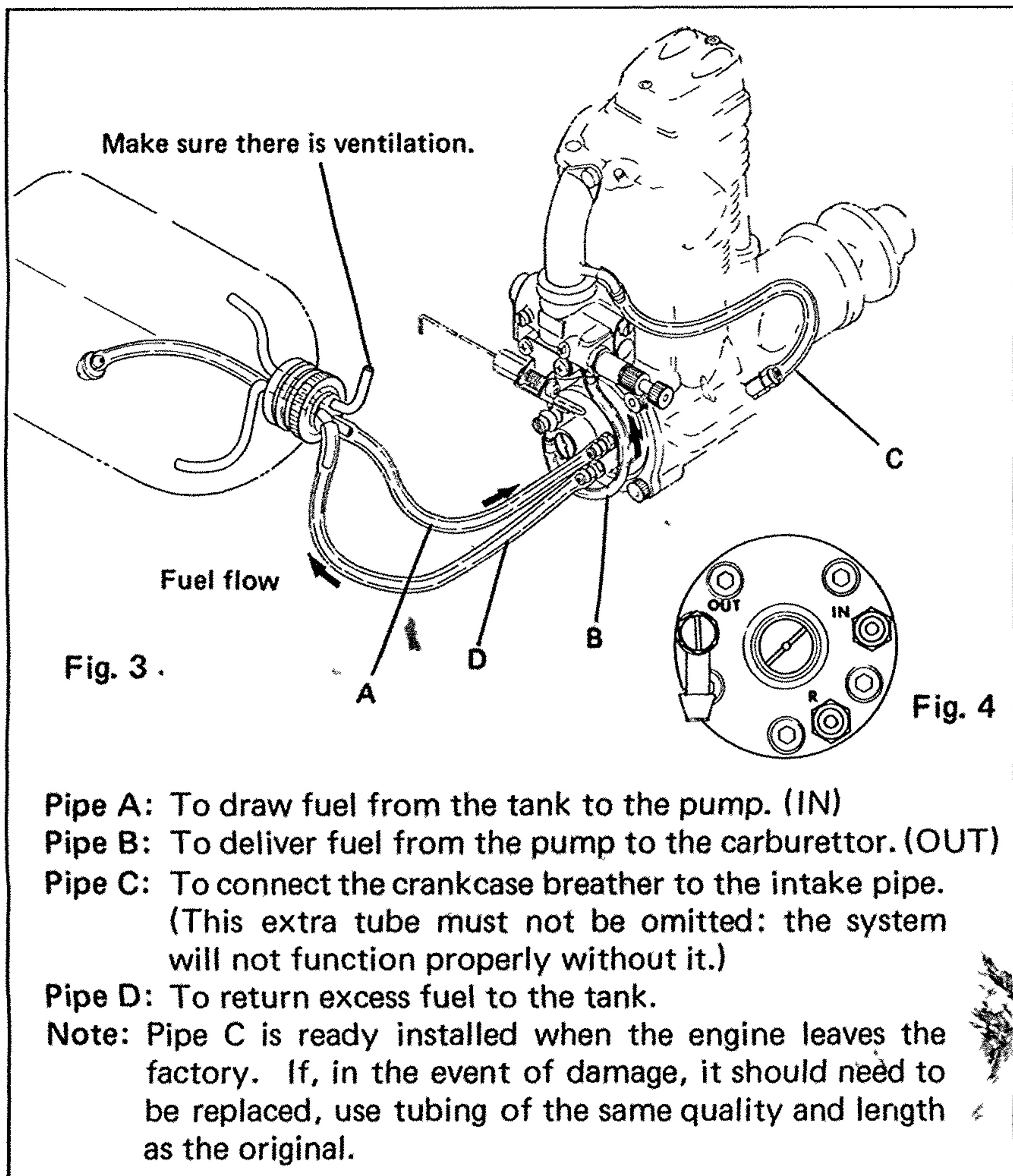

CARE OF FUEL PUMP – WARNINGS!

1. NEVER disassemble the pump. Its original performance may not be restored after reassembly.
2. The central adjusting screw is precisely set at the factory and then sealed with paint. NEVER MOVE THIS SCREW. If the screw is disturbed, it cannot be re-set at its optimum position without the aid of special instruments.
3. NEVER insert anything into the inlet or outlet nipples. This is likely to damage the pump and render it inoperative.
4. USE FUEL FILTERS. Any foreign matter entering the pump may interfere with its correct-functioning. Be sure to filter all fuel before filling the tank and, most important, use a good quality fine filter in the delivery tube between the tank and pump.
5. Do not bring your face near to the fuel-tank overflow (ventilation) pipe. If, when being started, the engine rotates in the reverse direction, fuel will spurt strongly from the overflow.

INSTALLATION OF PUMP SYSTEM

Here is an example of a typical installation. (Top view, upright engine installation)

Muffler pressurized fuel feed system is not necessary.

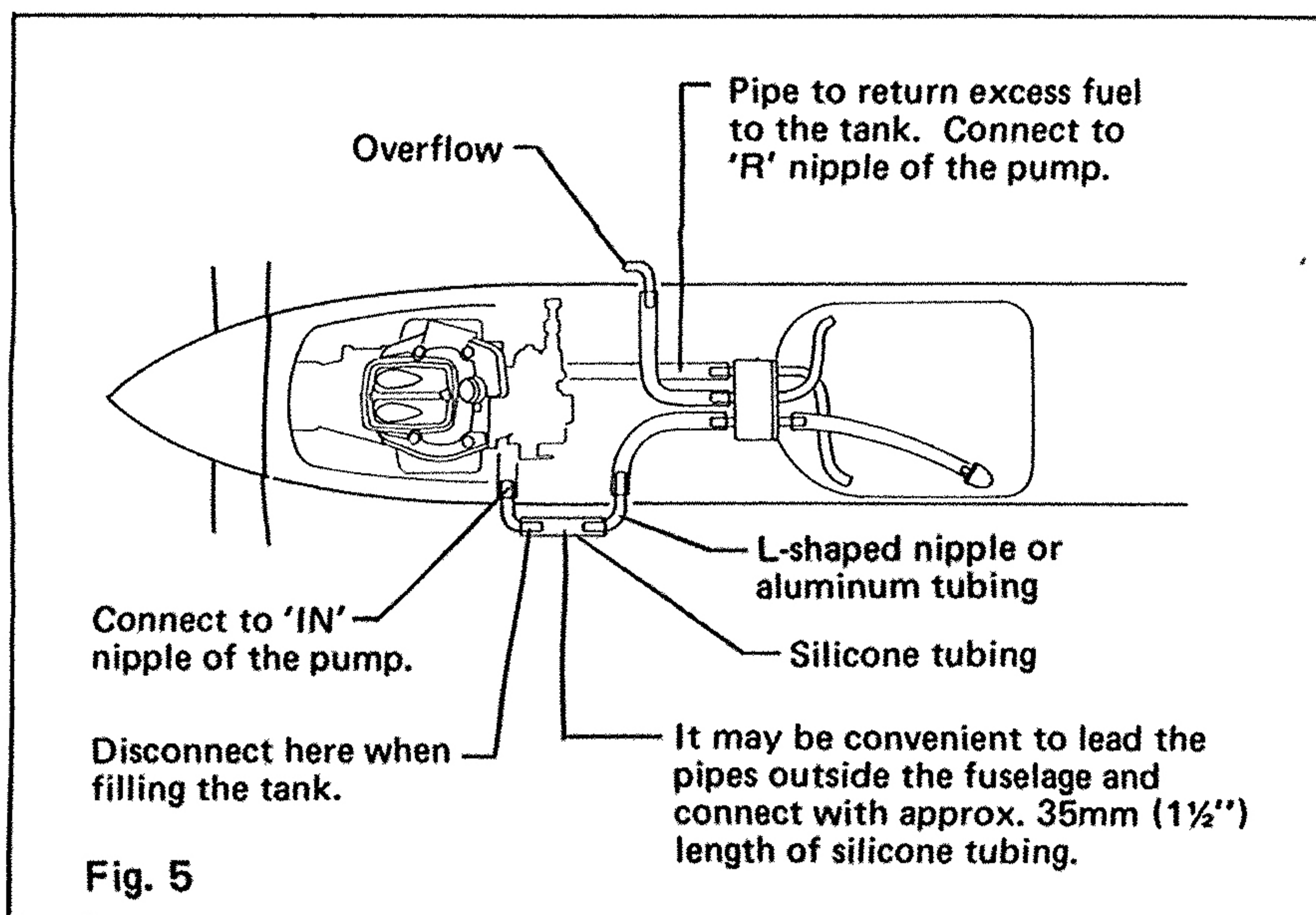

GLOWPLUG

An O.S. Type "F" glowplug (recommended) is fitted to the engine.

PROPELLER

The choice of propeller depends on the design and weight of the model and on the type of flying envisaged. Determine the best size and type after practical experiment. As starting points, suggested propellers are listed below.

Note: Smaller or larger props than those shown in the list can be used. However, it should be noted that propeller noise will increase as the r.p.m. increase.

For stunt models	13x11, 13x12, 14x10 or 14x11
For scale models	15x8, 16x6, 16x7, 17x6, 18x5, 18x6, 14x7 (3-blade) or 15x8 (3-blade)

For safety, keep your face and other parts of the body well away from the propeller when starting the engine or adjusting the needle-valve while the engine is running. Remember that the propeller turns through a much wider arc with the large sized propellers that this engine is capable of driving. Refer to the "Safety Instructions and Warnings" leaflet enclosed.

IMPORTANT: Use well balanced propellers and spinners only. An unbalanced propeller or spinner causes vibration and loss of power.

WARNING: There is always a danger, especially with nylon propellers (and depending on engine speed and weather conditions), of the propeller fracturing and a blade flying off and, obviously, this could cause serious injury. Therefore, never crouch over the engine when it is running and keep all onlookers well back and behind the model. If a spinner is used, make sure that the spinner notches are large enough to clear the propeller blades and so do not cut into and weaken the blade roots when the propeller nut is tightened.

There is also a risk, particularly with four-stroke engines, of the propeller flying off if the propeller nut loosens due to detonation or "knocking" when the engine is run too lean or under too heavy a load. Obviously this can also be very hazardous.

To combat this danger, we have developed the special Safety Propeller Locknut Assembly supplied with the FS-120 Surpass. This prevents the propeller from flying off, even if the propeller itself should slip or loosen.

1. Ream the propeller centre hole to 8mm dia. Make sure that the propeller is properly balanced.
2. Fit the propeller sleeve-nut and washer to propeller, screw onto shaft and tighten firmly with 17mm wrench supplied.
3. Finally, insert the Safety Propeller Locknut. Tighten Locknut firmly (but not with excessive force) using 14mm wrench.

IMPORTANT:

Regardless of the type of propeller being used, make a habit of always checking the tightness of the propeller before starting the engine. Remember that, especially with wooden propellers, there is a tendency for the material to shrink, or for it to be reduced by the serrated face of the drive hub.

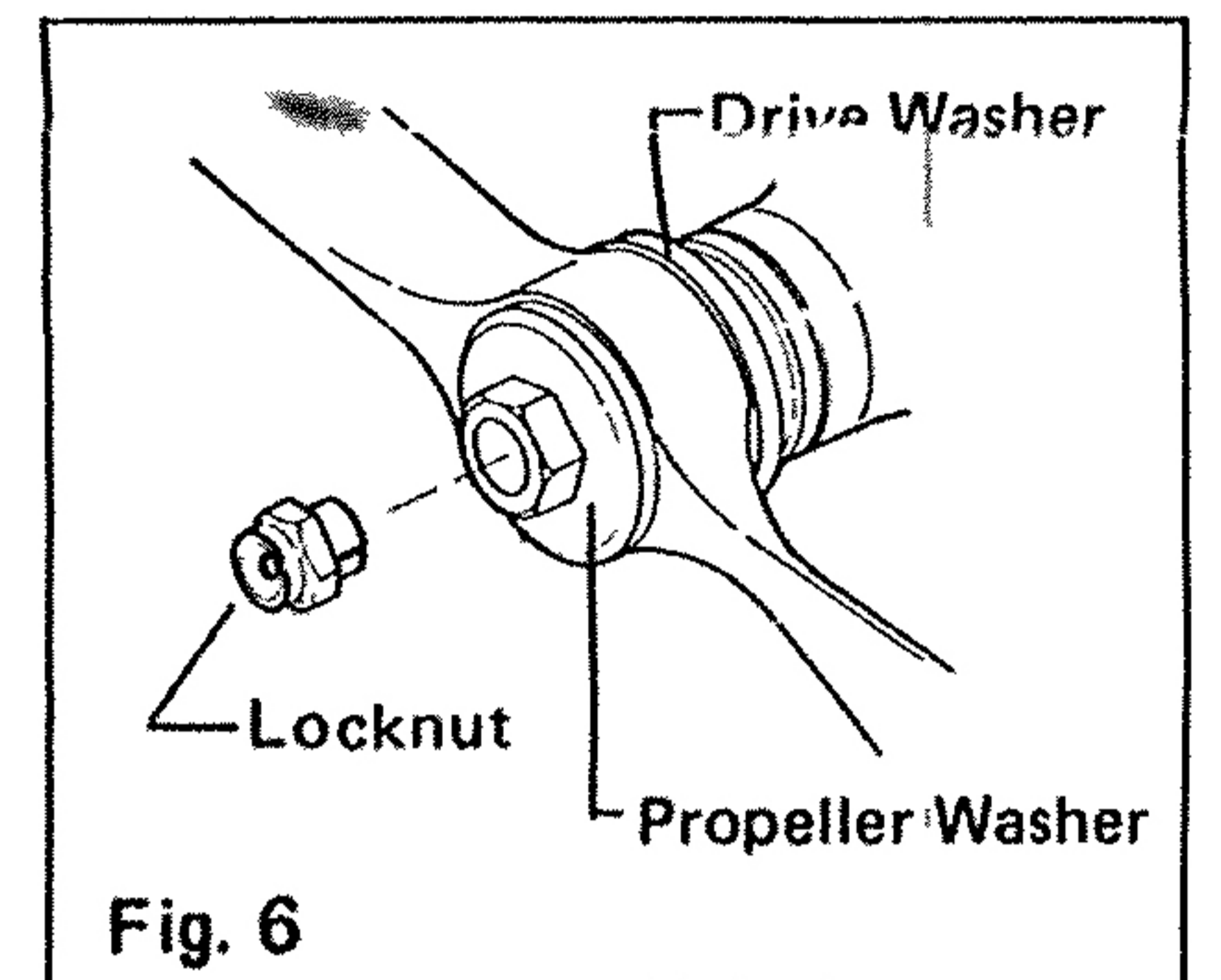

STARTING

It is preferable to use a heavy-duty electric starter, although hand-starting is also possible, as will be explained in a moment.

1. Open the throttle so that the throttle-arm is at one-quarter of its full throw and set the needle-valve 1½ turns open from the fully closed position.
2. Energize the glowplug and apply the electric starter after making sure that the battery leads are properly connected for counter-clockwise rotation. If the power of your starter is insufficient to immediately rotate the engine freely, turn the propeller clockwise ('backwards') until compression is felt, then, with the propeller in this position, try the starter again. This will enable the kinetic energy of the rotating propeller to assist in carrying the engine through its compression stroke. Also, make sure that your starter battery is in good condition and fully charged.

CAUTION: Never apply an electric-starter with the choke closed. Such an action will cause an excess quantity of fuel to be drawn into the cylinder and result in an hydraulic lock that may damage the engine.

3. When the engine starts, keep it running, initially, with the original needle-valve setting. If the engine slows down because the mixture is excessively rich, close the needle-valve slowly until the engine runs evenly. Then disconnect the battery from the glow-plug and close the needle-valve slowly so that revolutions increase. Adjust the needle-valve gradually. It should be noted that the speed of the engine does not instantly change with needle-valve adjustment because of the characteristics of the engine equipped with the pump. Abrupt adjustment of the needle-valve may cause the engine to stop.

The above starting procedure is standard for the FS-120 Surpass. However, the engine may be safely hand started – except when using a lightweight wooden propeller. For safety, be sure to use a "chicken-stick". The procedure is as follows.

1. The propeller should be fixed in such a way that it is positioned horizontally as compression is first felt when turning the propeller counter-clockwise.
2. Open the throttle valve fully and unscrew the needle-valve approximately one-and-one-half turns from the fully closed position.
3. Prime the engine by closing the choke valve and turning the propeller through 5 to 6 revolutions, depending on the length of pipe from tank to carburettor.
4. Turn the propeller counter-clockwise several times so that fuel is drawn well into the cylinder.
5. Gradually turn the propeller counter-clockwise until compression is felt. Leave the prop at this position.
6. Set the throttle at approximately 1/4 open.
7. Connect the glowplug battery and, using the chicken-stick, briskly swing the propeller clockwise from the position determined above and from the centre of the right blade. The engine will then bounce smartly in the counter-clockwise direction to the point where ignition and expansion of the charge takes place. If the engine stops, make sure that fuel is reaching the carburettor from the fuel tank, then repeat procedures 3) to 7). Correct priming is the secret of easy hand-starting.
8. When the engine starts, keep it running, initially, with the original needle-valve setting. If it slows down because the mixture is excessively rich, close the needle-valve slowly until the engine runs evenly. Then disconnect the battery from the glowplug and close the needle-valve slowly so that revolutions increase. Adjust the needle-valve gradually. Abrupt adjustment of the needle-valve may cause the engine to stop.
9. To re-start the engine when it is hot, after a run, first try just flipping the propeller, with the throttle in the idling position, after re-energising the glowplug. If the engine does not re-start, re-prime it by closing the choke valve while rotating the propeller once or twice until the cylinder becomes cool enough for restarting.

CAUTION: Do not connect the glowplug to the battery while priming.

Note: Excess fuel in the carburettor may drip into the engine compartment when the choke valve is reopened. Therefore, it is advisable to drill a drain hole in the bottom of the engine bay or cowling and to apply fuelproof paint to the surrounding surfaces to prevent fuel from penetrating the airframe structure.

RUNNING-IN ("Breaking-in")

All internal combustion engines benefit, to some degree, from extra care when they are run for the first few times — known as running-in or breaking-in. This is because the working parts of a new engine take a little time to settle down after being subjected to high temperatures and stress. However, as O.S. engines are made with the aid of the finest modern precision machinery and from the best and most suitable materials, only a very short and simple running-in procedure is required and can be carried out with the engine installed in the model.

For running-in, use the same sized propeller as you intend for flying your model.

Running-in procedure is as follows:

Start the engine and run it for about 5 seconds at around maximum r.p.m., then open the needle-valve 1/4 turn to produce a rich mixture for cooler, slower running, and run for 10 seconds at this setting. Keep the throttle fully open, using only the needle-valve to reduce speed. Repeat this procedure, alternately running the engine fast and slow with the needle-valve, but gradually extending the short periods of maximum speed running until two full tanks of fuel are consumed.

Note: Take care to avoid dusty and sandy locations. Dust and grit drawn into the engine will seriously damage its working parts.

Following the initial break-in on the ground, the engine should be given a period of moderately rich running in the air. For the first flights, have the needle-valve approximately 1/4 turn open from the peak r.p.m. setting, consistent with adequate take-off power and steady level flight and, if necessary, readjust the throttle trim on the transmitter so that the engine does not stop when the throttle is fully closed.

With each successive flight, close the needle-valve slightly, until, at the end of 10 flights, the needle-valve is set for maximum power. The carburettor can now be adjusted for optimum throttle performance following the instructions given in the next section.

Note: Remember that, while the engine is being run-in and the needle-valve is set on the rich side, the carburettor cannot be expected to show its best response. Therefore, avoid abrupt throttle operation at this stage.

THE O.S. TYPE C-12 CARBURETTOR

Three adjustable controls are provided on the Type C-12 carburettor fitted to the FS-120 Surpass. (See Photo 2.) These are as follows:

- **The Needle-Valve:** For adjusting the mixture strength when the throttle is fully open.
- **The Mixture Control Screw:** For adjusting the mixture strength at part-throttle and idling speeds, to obtain steady idling and smooth acceleration to medium speeds.
- **The Throttle Stop Screw:** For establishing the minimum idling speed.

Provisional setting

Before starting the engine, open the needle-valve approximately one-and-one-half turns from the fully closed position.

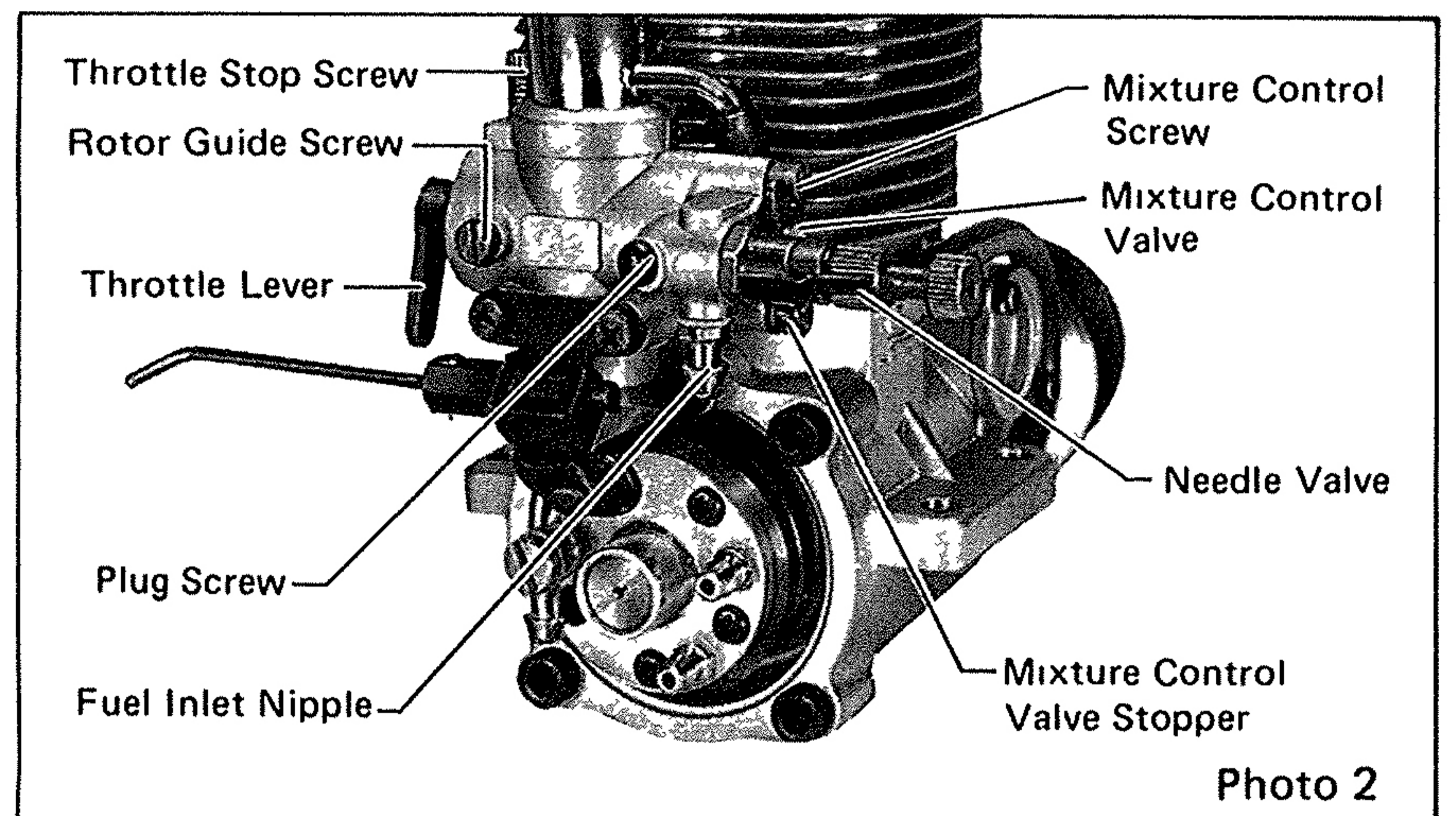

ADJUSTING THE CARBURETTOR

1. Set the throttle lever very slightly open from the idle position (see Fig. 7) and start the engine in the usual way. It is preferable to have the throttle only slightly open, to avoid unnecessarily high revolutions when the engine starts.
2. Now open the throttle fully and gradually close the needle-valve until the engine is running at its maximum speed.

Note: Make sure that the engine is fully "run-in" before operating it continuously at full power. (See RUNNING IN section.)

3. Having set the needle-valve as described above, close the throttle and run the engine at idling speed for approximately 5 seconds, then steadily move the throttle to the fully open position by means of the throttle servo.

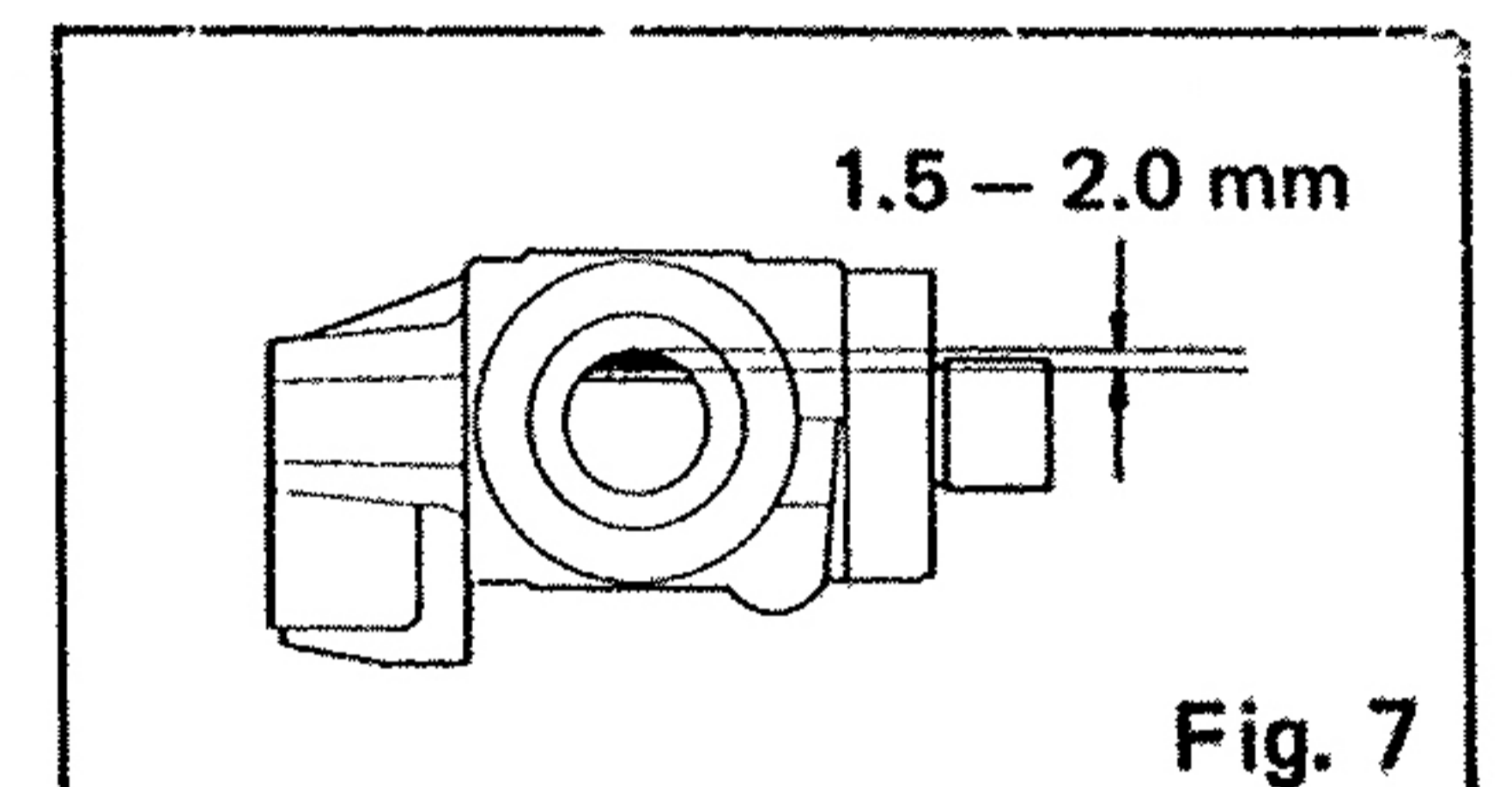

- (a) If, at this point, the engine hesitates before picking up speed, with a low-pitched exhaust note and an excess of exhaust smoke, it is probable that the idling mixture is too rich. In this case, it will be necessary to turn the mixture control screw clockwise about 5 degrees.
- (b) If, on the other hand, the engine hesitates or even appears to cease firing for an instant, before increasing speed, it is probable that the idling mixture is too lean. In this case, it will be necessary to turn the mixture control screw counter-clockwise about 5 degrees.

Note: Please observe the symptoms carefully for the brief moments immediately after opening the throttle from the idling position.

Do not turn the mixture control screw more than 5 degrees at a time. Carry out adjustments progressively and patiently, remembering the symptoms of rich and lean running, quoted above, until the engine responds quickly and positively to the throttle.

4. The throttle stop screw is for fixing the minimum idling speed. If, after carrying out mixture adjustments, the idling speed is found to be too high, the throttle stop screw should be turned counter-clockwise until the desired idling speed is obtained.

Note: Once the correct carburettor settings have been established, it should be unnecessary to alter them. Such slight needle-valve readjustments as may be required to compensate for variations in atmospheric conditions, will not normally affect the other two controls. Slight readjustments may be necessary for optimum performance if different types of fuel, glow-plugs or propellers are used. In this case, begin by flying the model with the needle-valve approximately 1/8 to 1/4 turn open from the peak r.p.m. as a safety measure, then readjust as necessary.

CARBURETTOR CLEANLINESS

The correct functioning of the carburettor depends on its small fuel orifices remaining clear. The minute particles of foreign matter that are present in any fuel can easily partially obstruct these orifices and upset mixture strength so that engine performance becomes erratic and unreliable.

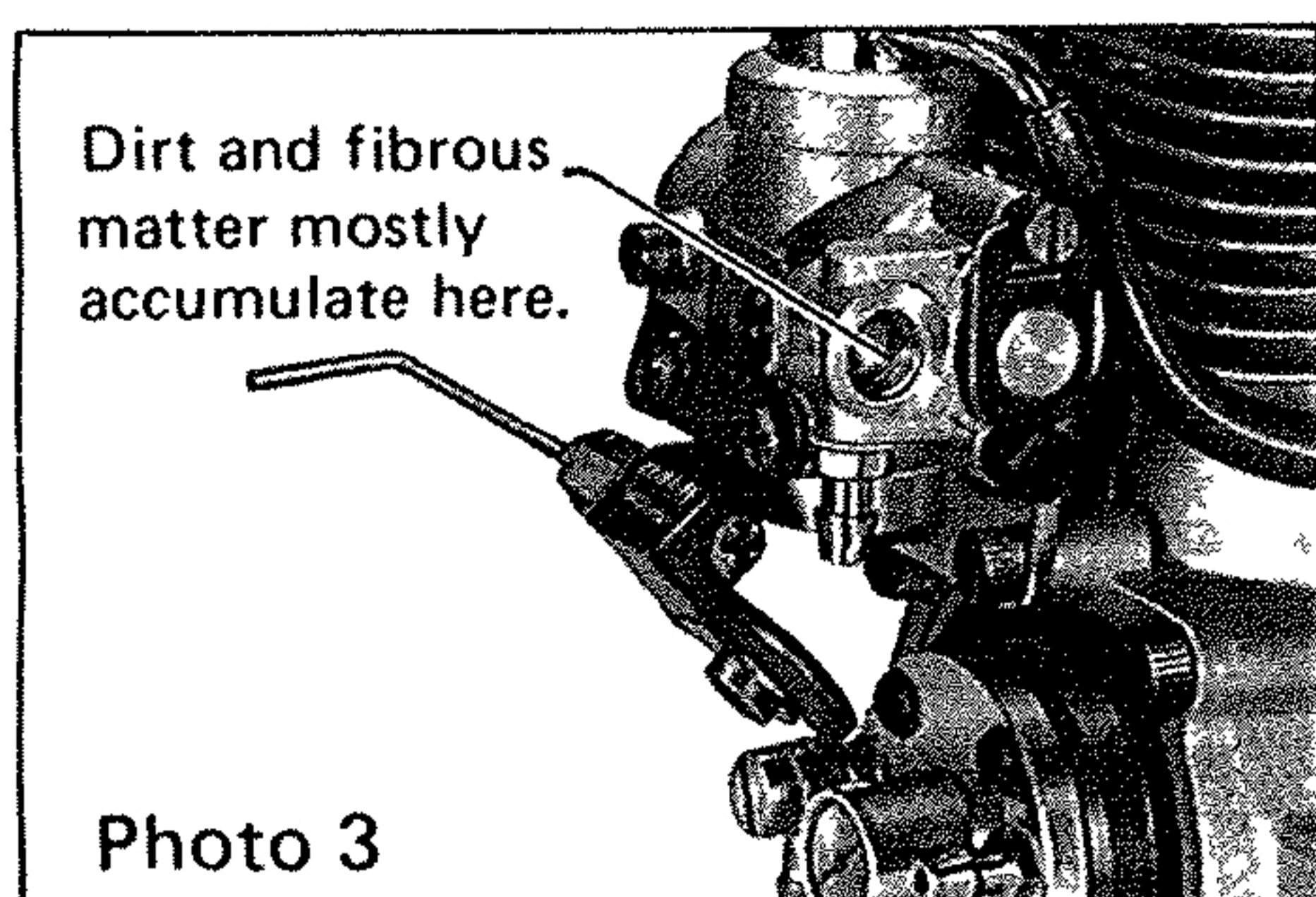

It is recommended that fuel is passed through a filter when the tank is filled and that a good in-line filter is installed between the fuel tank and carburettor and, furthermore, that this filter is frequently cleaned to remove dirt and lint that accumulates on the filter screen. Finally, occasionally remove the needle-valve holder from the carburettor, using the wrench supplied, and extract any remaining foreign matter that may have lodged in the location shown in Photo 3.

VALVE CLEARANCE ADJUSTMENT

Valve clearances are correctly set before any O.S. four stroke engine leaves the factory and, in normal use, will seldom require adjustment. However, if, after a considerable amount of running time has accumulated, a loss of power is detected, or if the engine has to be disassembled or repaired as a result of a crash, valve clearances should be checked and readjusted as necessary. For checking and adjusting the valve clearances, a valve adjusting kit is supplied with the engine.

Note: Valve clearances on this engine must be checked and re-set only WHEN THE ENGINE IS COLD.

1. Remove the rocker cover by unscrewing two Allen screws from the rocker box on top of the cylinder head.
2. Turn propeller until compression is felt, then turn it one quarter turn and stop. Both valves should now be closed.
3. The required valve clearance is between 0.04 mm and 0.10 mm (.0015 to .004 in.) measured between the valve stem and rocker-arm. Use the 0.04 mm (thinner one) and 0.10 mm (thicker one) feeler gauges to check clearance. The 0.04 mm feeler should pass through the gap: the 0.10 mm gauge should not.

4. If the gap is found to be less than 0.04 mm or more than 0.10 mm, carefully slacken the locknut on the rocker-arm with the 5 mm wrench supplied, turn adjusting screw with 1.5 mm Allen key to open or close gap, then retighten locknut. Finally, re-check gap and readjust if necessary.

IMPORTANT: Incorrect valve clearances may cause difficult starting (due to valve not closing properly) or loss of power (due to valve not opening sufficiently).

NEEDLE VALVE EXTENSION

The needle-valve supplied with this engine is designed to incorporate an extension so that, when the engine is enclosed within the fuselage, the needle-valve may be adjusted from the outside. An L-shaped rod, of 1.6 – 1.8 mm dia. and appropriate length, should be inserted into the needle's centre hole and secured by tightening the set-screw in the needle-valve knob with the small Allen key provided.

CARE OF YOUR FS-120 SURPASS

Do not run the engine too lean in the air. Running the engine too lean will cause overheating and the risk of damage. It also carries a greater risk of internal corrosion. The acid products of combustion are increased with some fuels containing nitromethane and synthetic lubricants at high temperatures and, since a proportion of these by-products enter the crankcase with the blow-by gases from the combustion chamber, this means a greater risk of corroding the steel parts of the engine – i.e. the formation of rust.

Equally, however, the engine should not be left "wet" with fuel by stopping it after excessively rich mixture running, or over-cooled following prolonged idling. At the conclusion of a flying session, let the engine run for a few moments at full throttle with the correct needle setting, to bring it up to normal running temperature, then cut off the fuel supply – preferably by removing the fuel line from the carburettor.

Extra protection against cold corrosion should then be given by injecting some corrosion-inhibiting or moisture-displacing oil, or light machine oil, through the crankcase breather and rotating the crankshaft for several revolutions to draw the oil into the bearings, cam gear, etc.

Keep the engine in a clean, dry atmosphere when it is not in use. Do not dismantle the engine needlessly.

PARTS LIST

Code No.	Description	Code No.	Description
45501020	Crankcase	45560030	Intake Valve Assembly
45501110	Cam Cover	45560040	Exhaust Valve Assembly
45502020	Crankshaft	45561010	Rocker Arm Assembly
45503100	Cylinder Liner	45561401	Rocker Support Assembly
45503210	Piston	45562010	Camshaft
45503400	Piston Ring	45564000	Cam Follower
45504020	Cylinder Head (w/ Valve Ass'y)	45566000	Push Rod
45504110	Cylinder Head	45566101	Push Rod Cover Assembly
45504210	Rocker Cover	45526010	Exhaust Header Pipe Assembly
45505010	Connecting Rod	45569410	Intake Pipe Assembly
45506010	Piston Pin	45583010	Carburettor Complete (Type C12)
29017004	Piston Pin Retainer	45583110	Carburettor Stay (w/ Screws)
45508020	Drive Washer (w/ Key)	72503001	Pump Unit (PG-01)
45508200	Woodruff Key	45571000	Universal Nipple S (3.5) Ass'y
45520000	Thrust Washer	71615009	Glow Plug Type "F"
45510100	Safety Propeller Locknut Assembly	45584010	Choke Valve Assembly
45513010	Screw Set	45525010	Silencer
45514010	Gasket Set	72200060	Valve Adjusting Kit
29031009	Crankshaft Ball Bearing (Front)	*45524000	Spinner Nut
29130005	Crankshaft Ball Bearing (Rear)	*71904200	Radial Motor Mount
45231100	Camshaft Bearing		

* Optional parts

The specifications are subject to alteration for improvement without notice.

O.S. ENGINES MFG. CO., LTD.

6-15 3-chome Imagawa Higashiumiyoshi-ku
Osaka 546, Japan. TEL. Osaka (06) 702-0225

© Copyright 1987 by O.S. Engines Mfg. Co., Ltd.
All rights reserved. Printed in Japan