

Knock Sensor replacement for Toyota Avalon Second Generation (2000-2004) 3.0-liter 1MZ-FE V6 engine equipped with VVT-I Shared with the Toyota Sienna, Lexus RX300, Lexus ES, and the Toyota Highlander

This is a moderately difficult job due to 2-steps: removing and installing the upper bolt on the No. 1 engine hanger. The bolt is located in the narrow gap between the air intake chamber and the firewall. It is very difficult to get to because it's blocked by the power steering pipe and nestled in a channel-shaped bracket that prevents you from putting a box or open-end wrench on it. Every time I have done this service I have spent an inordinate amount of time on those two steps!

I've now done this repair three times on my 2000 Avalon (with 225,000 miles), twice in the last year because of using a bad knock sensor/harness combination purchased on Amazon. I think the harness was the real culprit but in either case the necessity to replace everything was the same. I've found some good techniques that make this a much easier 3-4 hour job using nothing but pretty standard tools.

I think the procedures and tips I have captured below make these two steps significantly easier but they are still a pain in the rear to accomplish. Good luck and happy driving some of the most reliable cars on the road.

Mark Lukens
©2020

KNOCK SENSOR COMPONENTS

SF065-02

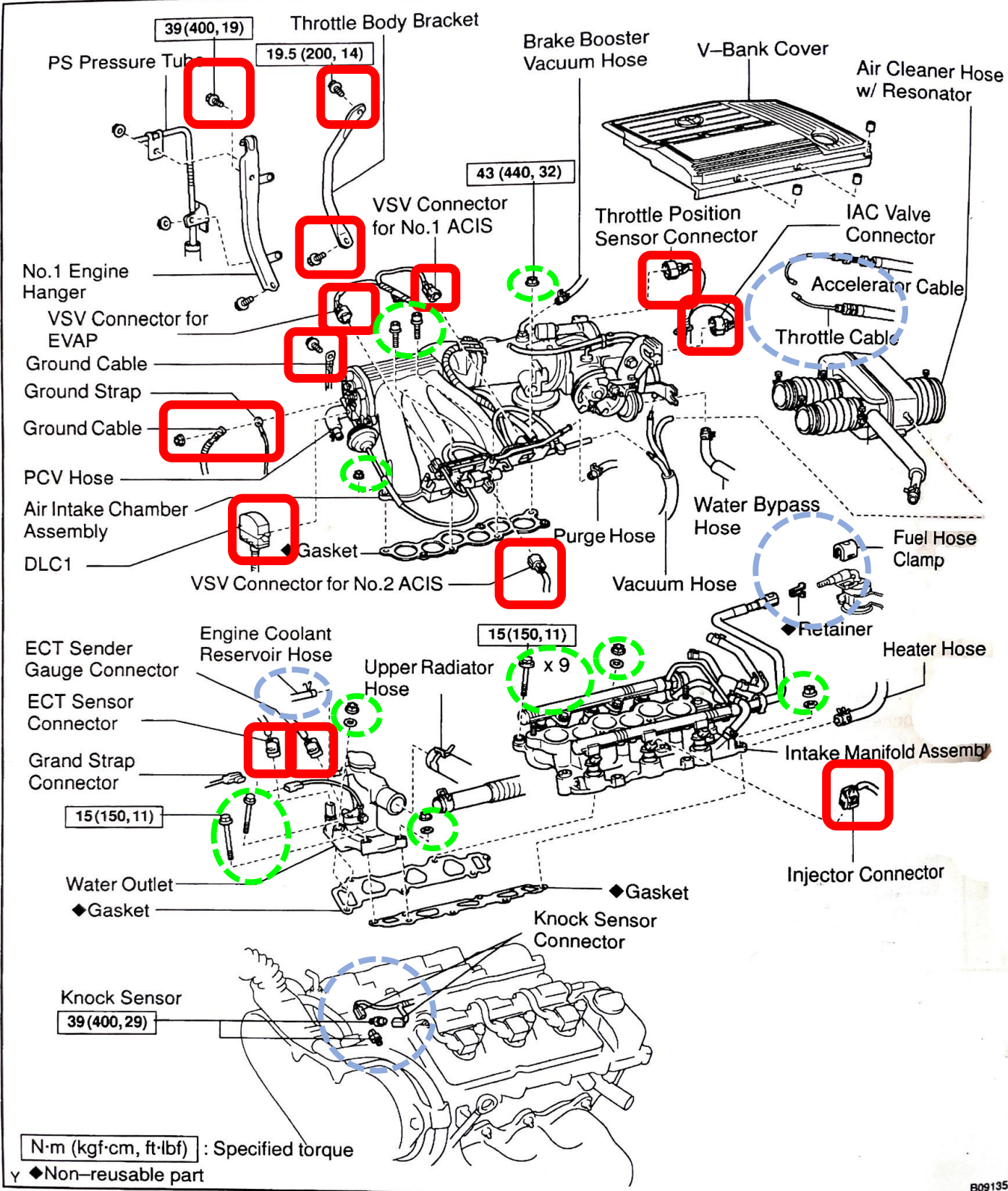

B09135

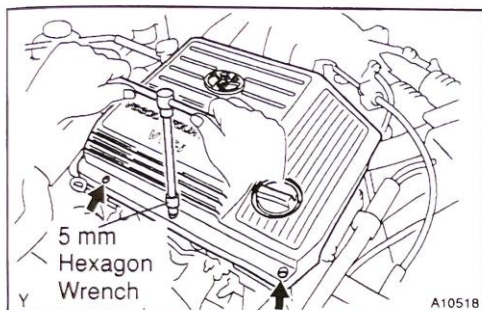

INSPECTION

1. **REMOVE V-BANK COVER**
 - (a) Using a 5 mm hexagon wrench, remove the 3 cap nuts.
 - (b) Loosen the V-bank cover fastener counterclockwise.
 - (c) Remove the V-bank cover.
2. **REMOVE AIR CLEANER HOSE WITH RESONATOR**
3. **REMOVE INTAKE MANIFOLD ASSEMBLY AND WATER OUTLET (See page EM-31)**

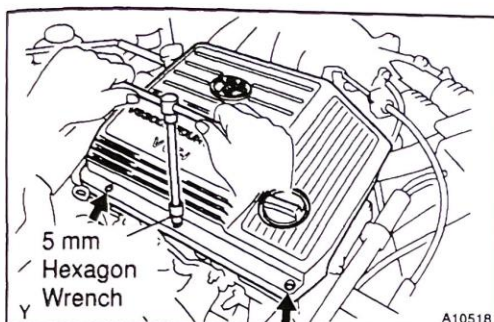

6. **REMOVE V-BANK COVER**
 - (a) Using a 5 mm hexagon wrench, remove the 3 cap nuts.
 - (b) Loosen the V-bank cover fastener counterclockwise.
 - (c) Remove the V-bank cover.
7. **REMOVE AIR CLEANER HOSE WITH RESONATOR**
8. **REMOVE AIR INTAKE CHAMBER ASSEMBLY**
 - (a) Disconnect the accelerator cable.
 - (b) Disconnect the throttle cable.
 - (c) Disconnect the throttle position sensor connector.
 - (d) Disconnect the IAC valve connector.
 - (e) Disconnect the No.1 VSV connector for the ACIS.
 - (f) Disconnect the No.2 VSV connector for the ACIS.
 - (g) Disconnect the VSV connector for the EVAP.
 - (h) Disconnect the DLC1 from the bracket on the intake air control valve.

- (i) Remove the 2 nuts, and disconnect the PS pressure tube from the No.1 engine hanger.

Don't do this - unnecessary

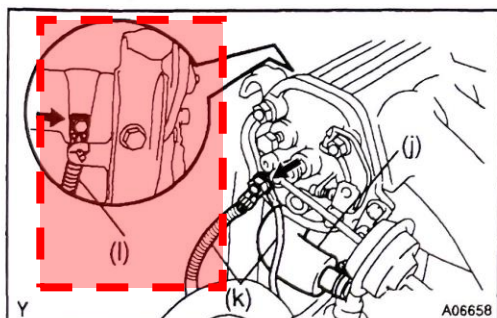

- (j) Disconnect the PCV hose from the PCV valve on the RH cylinder head.
- (k) Disconnect the ground strap and cable from the intake air control valve for the ACIS.

- (l) Disconnect the ground cable from the air intake chamber.

Don't do this now! Easier to do later

TIP: When I disassemble something as complicated as this I always bag all the parts and fasteners that I remove at each step in a separate baggie with a description of where the parts came from and what order they were bagged. This only takes a few seconds and dramatically speeds up the reinstallation process and reduces errors.

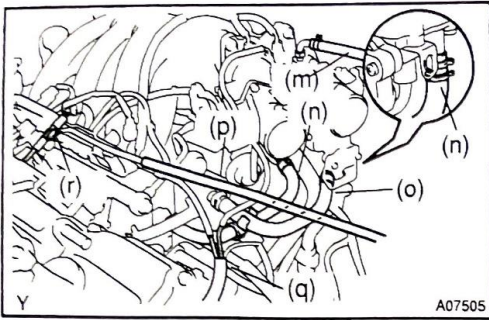

- (m) Disconnect the brake booster vacuum hose from the throttle body.
- (n) Disconnect the 2 water bypass hoses from the throttle body.
- (o) Disconnect the air assist hose from the throttle body.
- (p) Disconnect the purge hose from the pipe on the emission control valve set.
- (q) Disconnect the 2 vacuum hoses from the vacuum tank for the ACIS.
- (r) Disconnect the engine wire clamp from the emission control valve set.



- (s) Remove the 2 bolts and No.1 engine hanger.

NOTE: Only remove the top bolt – use a 14mm socket and a PowerBUILT socket lever to reach behind the intake chamber and loosen the bolt. Once you break it loose you can then put just the socket back on with your fingers and remove it by hand. It helps to wiggle the engine hanger bracket while removing the bolt.

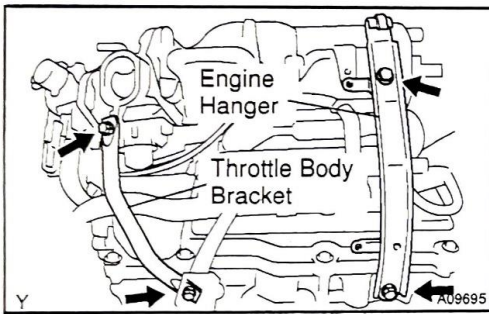

- (t) Remove the 2 bolts and throttle body bracket.

NOTE: These two are easy to remove and you should do so.

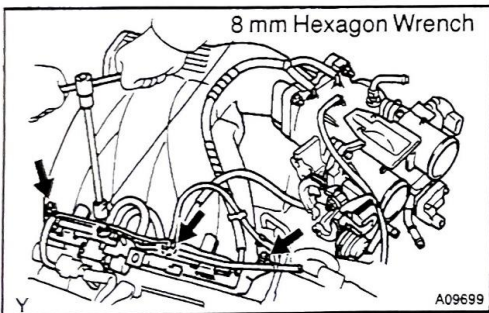

- (u) Using an 8 mm hexagon wrench, remove the 2 bolts, 2 nuts, the air intake chamber assembly and gasket.

NOTE: Now is the time to **remove the rear ground strap** off the back of the air intake chamber! Once you have the bolts and nuts off the chamber and it's loose, move it slightly forward and set it down on the engine. You can now easily remove the rear ground strap with a 10mm wrench.

9. REMOVE INTAKE MANIFOLD ASSEMBLY

- (a) Disconnect the 6 injector connectors.
- (b) Disconnect the fuel inlet hose from the fuel filter.

NOTE: See notes on next page on how to disconnect the fuel line from filter

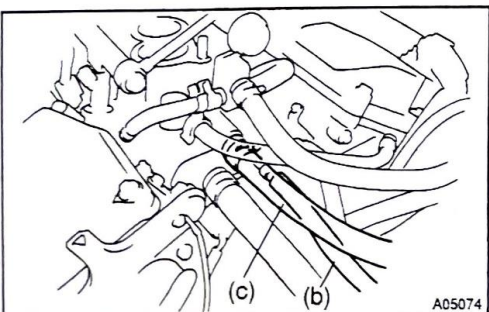

- (c) Disconnect the heater hose from the intake manifold.

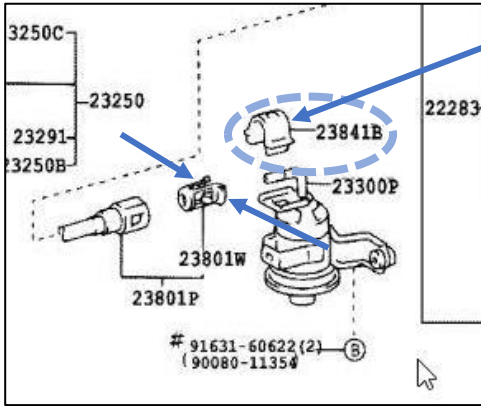

- 1) Use a pair of pliers to remove the coupler cover (23841B) if present. Squeeze both side in and lift.
- 2) Twist the fuel line until you can see both tabs on the quick release connector. Then squeeze together both tabs on the end of the fuel line coupler. The fuel line should easily slide off the end of the tube.

EM-33

ENGINE MECHANICAL - CYLINDER HEAD

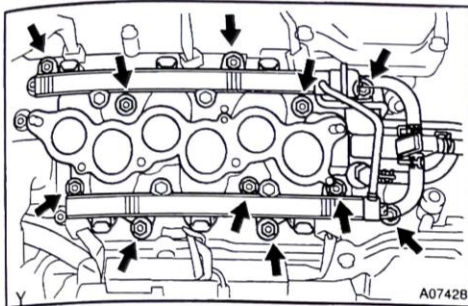

14mm hex head bolts and nuts

14mm hex head bolts and nuts

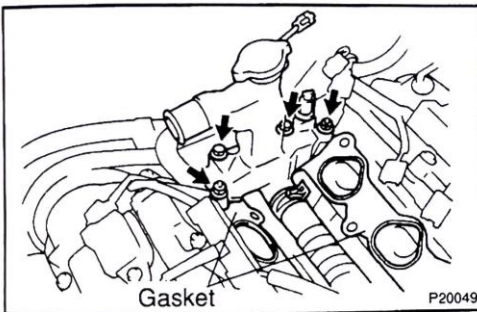

Gasket

P20049

- (d) Remove the 9 bolts, 2 nuts, 2 plate washers, the intake manifold, delivery pipes and injectors assembly.

NOTE: The 2 nuts also have washers under them. Be careful not to drop them or have them fall into one of the intake ports below the intake manifold. I like to stuff paper towels into the intake ports to protect them at this point.

10. REMOVE WATER OUTLET

- (a) Disconnect the ECT sender gauge connector.
- (b) Disconnect the ECT sensor connector.
- (c) Disconnect the ground strap connector.
- (d) Disconnect the upper radiator hose.
- (e) Disconnect the engine coolant reservoir hose.
- (f) Remove the 2 bolts, 2 nuts and 2 plate washers.
- (g) Disconnect the water bypass hose, and remove the water outlet.
- (h) Remove the 2 gaskets.

NOTE: On my 2000 Avalon the water outlet is trapped by the RH engine bracket. I had to remove the two long bolts and a short bolt that goes into the side of the water outlet casting. I was then able to move the engine bracket to the side (without detaching the Engine Moving Control Rod) and proceed to remove the water outlet.

NOTE: The engine mounting bracket bolts were very tight on my vehicle and I had to use a 6-point socket to get them loose without rounding the bolt heads.

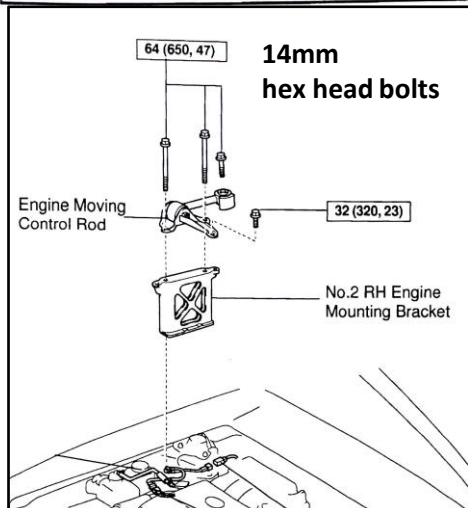

14mm hex head bolts

Engine Moving Control Rod

No.2 RH Engine Mounting Bracket

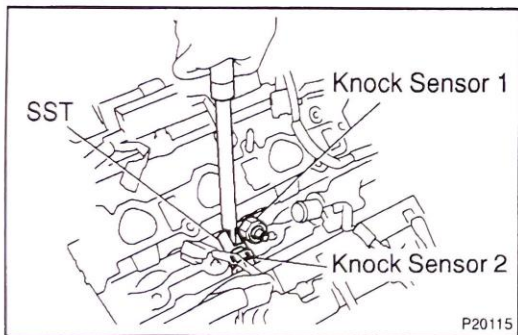

4. REMOVE KNOCK SENSORS

- (a) Disconnect the knock sensor connector.
- (b) Using SST, remove the knock sensor.
SST 09817-16011

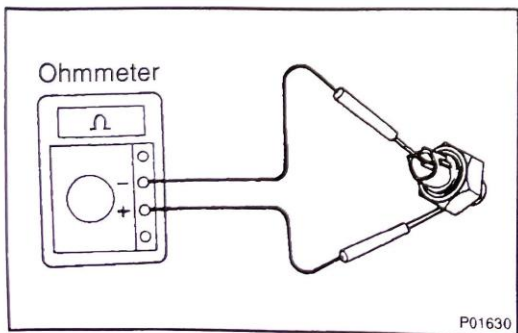

5. INSPECT KNOCK SENSORS

Using an ohmmeter, check that there is no continuity between the terminal and body.

If there is continuity, replace the sensor.

6. REINSTALL KNOCK SENSORS

- (a) Using SST, install the knock sensor.
SST 09817-16011

Torque: 39 N·m (400 kgf·cm, 29 ft·lbf)

- (b) Connect the knock sensor connector.

NOTE: The knock sensors can be removed with a 27mm (1-1/16") socket. I blow out the threads before I install the new ones. I tighten them by hand as far as they go before I use a torque wrench to set them at the proper torque. I applied dielectric grease to the sensor connectors as well as the connector on the other end of the harness. You can purchase a small foil packet of dielectric grease at the auto parts store.

NOTE: Before you reassemble the engine make sure you remove any of the old gasket material from the heads and the intake manifold. Be very careful (if you use a putty knife to scrape of the old gasket) to avoid scratching the aluminum surfaces. I cleaned up all the surfaces with a brass wire brush and wiped them all off with a cloth. I also use a compressor to blow out any FOD from the intake ports before I start to reassemble the engine.

NOTE: Do not over-torque the bolts on the water outlet, intake manifold or intake chamber. Over tightening the bolts can damage the gaskets!

Follow the manufacturer's torque recommendations. The proper torque values can be found in the illustrations and directions in this document.

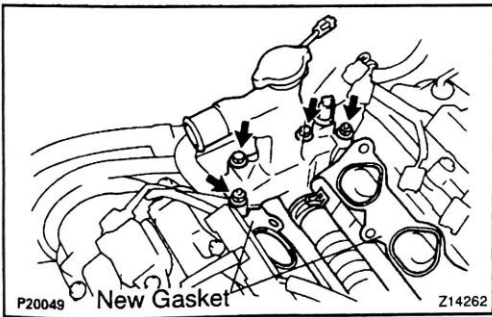

25. INSTALL WATER OUTLET

- (a) Install 2 new gaskets.
- (b) Connect the water outlet to the bypass hose.
- (c) Install the water outlet with the 2 bolts, 2 nuts and 2 plate washers. Alternately tighten the bolts and nuts.

Torque: 15 N·m (150 kgf·cm, 11 ft·lbf)

NOTICE:

Do not scratch the seal surface of the water outlet with the stud bolt.

- (d) Connect the ECT sender gauge connector.
- (e) Connect the ECT sensor connector.
- (f) Connect the ground strap connector.
- (g) Connect the upper radiator hose.
- (h) Connect the engine coolant reservoir hose.

Don't forget to reinstall the clamps on the water bypass hose!

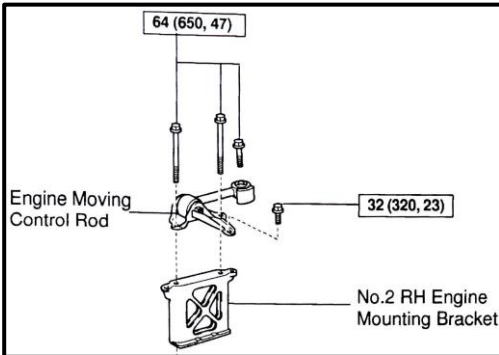

Once you have the water outlet installed you can reinstall the RH engine bracket, assuming you had to remove it during disassembly. The torque for the those bolts is 47 lbs. The torque going into the water outlet is 23 ft-lbs.

Be careful installing the intake manifold to avoid dropping anything into the intake ports. Remember to put the washers under the 2 nuts on the intake manifold.

EM-68

ENGINE MECHANICAL – CYLINDER HEAD

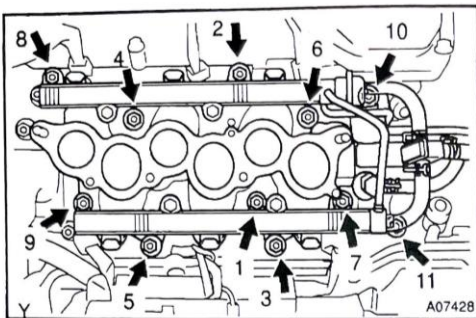

26. INSTALL INTAKE MANIFOLD ASSEMBLY

- (a) Install the intake manifold, delivery pipe and injectors assembly with the 9 bolts, 2 plate washers and 2 nuts. Uniformly tighten the bolts and nuts in several passes and in the sequence shown.

Torque: 15 N·m (150 kgf·cm, 11 ft·lbf)

- (b) Connect the fuel inlet hose to the fuel filter.

Be sure to reconnect all 6 injector connectors before proceeding to air intake chamber installation.

- (c) Connect the heater hose to the intake manifold.

27. RETIGHTEN WATER OUTLET MOUNTING BOLTS AND NUTS

Tighten the 2 bolts and 2 nuts.

Torque: 15 N·m (150 kgf·cm, 11 ft·lbf)

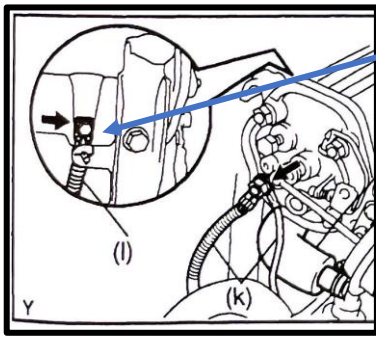

NOTE: Getting the rear ground strap attached can be very difficult once the air intake chamber is bolted in place. I suggest that you lay the air intake chamber on top of the intake manifold (not on the studs but several inches forward) and then attach the rear ground strap. After the strap is attached (10mm bolt head) proceed to the next step.

NOTE: Getting the upper hanger bolt started on the No. 1 engine hanger can be **VERY DIFFICULT!** I suggest that you get the air intake chamber bolts started a couple of turns but **DON'T tighten them AT ALL!**

This allows you to rock the air intake chamber up and down which greatly simplifies getting the top bolt on the No. 1 engine hanger started. Once that hanger bolt is started you can tighten up the air intake chamber per the instructions below.

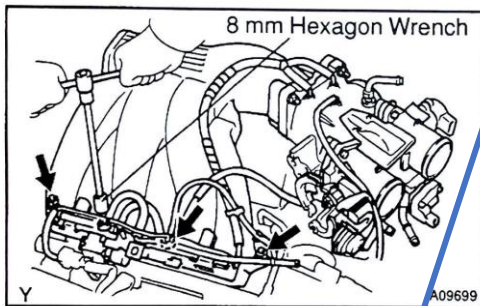

28. INSTALL AIR INTAKE CHAMBER ASSEMBLY

(a) Using an 8 mm hexagon wrench, install a new gasket and the air intake chamber assembly with the 2 bolts and 2 nuts. Uniformly tighten the bolts and nuts in several passes.

Torque: 43 N·m (440 kgf·cm, 32 ft·lbf)

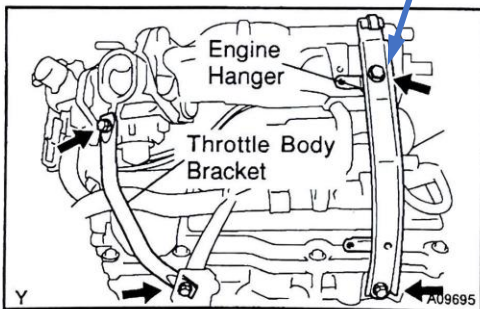

(b) Install the No.1 engine hanger with the 2 bolts.

Torque: 39 N·m (400 kgf·cm, 29 ft·lbf) (14mm)

(c) Install the throttle body bracket with the 2 bolts.

Torque: 19.5 N·m (200 kgf·cm, 14 ft·lbf) (12mm)

(d) Connect the PCV hose to the PCV valve on the RH cylinder head.

(e) Connect the ground strap and cable to the intake air control valve for the ACIS.

(f) Connect the ground cable and strap with the nut.

Torque: 14.5 N·m (145 kgf·cm, 10 ft·lbf)

DONE in previous step

(g) **Connect the ground cable to the air intake chamber.**

(h) Connect the brake booster vacuum hose to the throttle body.

(i) Connect the 2 water bypass hoses to the throttle body.

(j) Connect the air assist hose to the throttle body.

(k) Connect the purge hose to the emission control valve set.

(l) Connect the 2 vacuum hoses to the vacuum tank for ACIS.

(m) Connect the engine wire clamp to the emission control valve set.

- Not necessary** (n) Install the PS pressure tube with the 2 nuts.
- (o) Connect the throttle position sensor connector.
 - (p) Connect the IAC valve connector.
 - (q) Connect the No.1 VSV connector for the ACIS.
 - (r) Connect the No.2 VSV connector for the ACIS.
 - (s) Connect the VSV connector for the EVAP.
 - (t) Connect the DLC1 to the bracket on the intake air control valve.
 - (u) Connect the throttle cable.
 - (v) Connect the accelerator cable.
- 29. INSTALL AIR CLEANER CAP HOSE WITH RESONATOR**
- 30. INSTALL V-BANK COVER**
- (a) Using a 5 mm hexagon wrench, install the V-bank cover with the 3 cap nuts.
 - (b) Press down the V-bank cover fastener.

NOTE: Make sure that you add extra engine coolant to the reservoir as the engine will suck some in the first few times it heats up and cools down. I run the cabin heater on high a few times when I first drive it to ensure that coolant is circulating throughout the entire system.

- 34. FILL WITH ENGINE COOLANT**
- 35. START ENGINE AND CHECK FOR LEAKS**
- 36. VEHICLE ROAD TEST**
Check for abnormal noise, shock, slippage, correct shift points and smoothly operation.
- 37. RECHECK ENGINE COOLANT LEVEL**

Questions and comments are welcome. You can send them to me at: malukens@yahoo.com